

10 -3220-

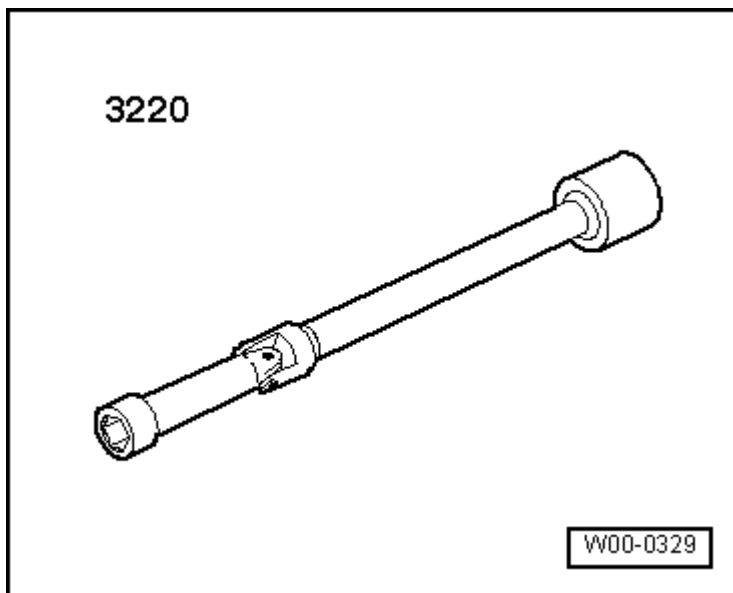

-V.A.G 1763-
-V.A.G 1763/5-

30 °C

. 12,5

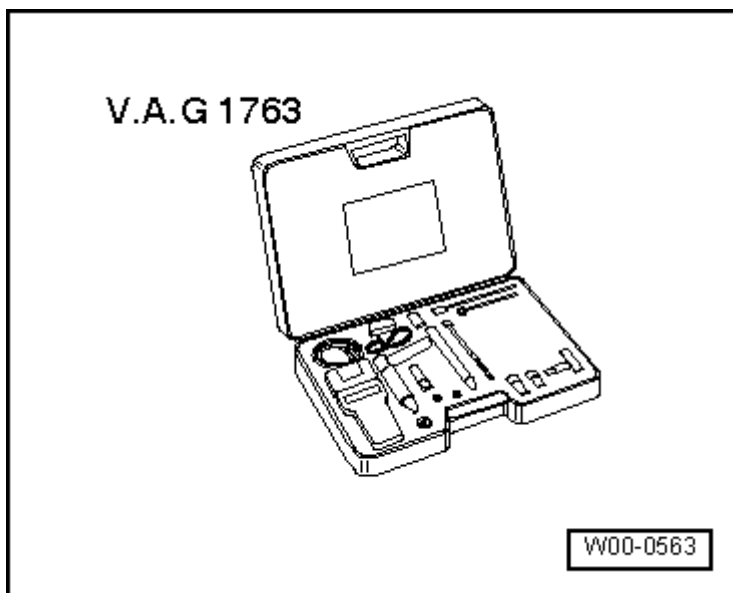

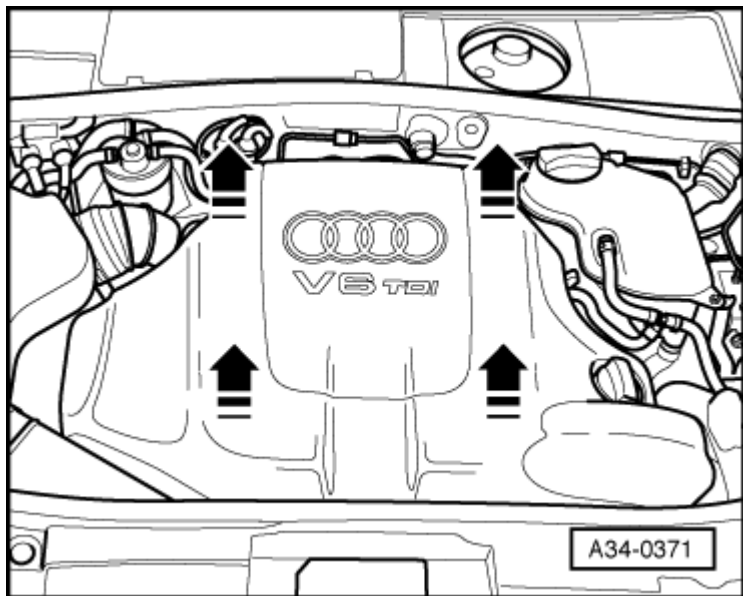

3220- 10 -
 -V.A.G 1763/5-
 -V.A.G 1763-

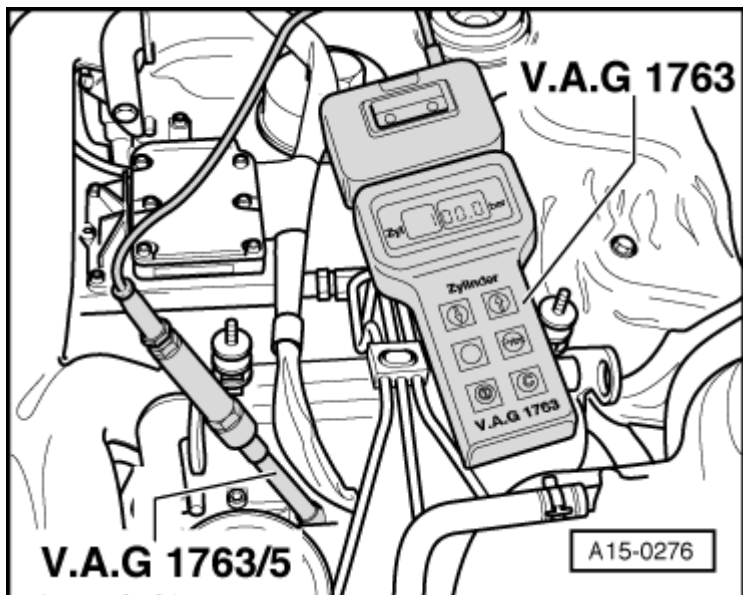

AKE, AYM, BAU, BCZ, BFC	26 ÷ 29	19	.5
BDG, BDH	24 ÷ 27	17	.5

VAS 5051.